A rangewide phylogeography of Hermann's tortoise, *Testudo hermanni* (Reptilia: Testudines: Testudinidae): implications for taxonomy

UWE FRITZ, MARKUS AUER, ALBERT BERTOLERO, MARC CHEYLAN, TIZIANO FATTIZZO, ANNA K. HUNSDÖRFER, MARCOS MARTÍN SAMPAYO, JOAN L. PRETUS, PAVEL ŠIROKÝ & MICHAEL WINK

Accepted: 25 May 2006
doi:10.1111/j.1463-6409.2006.00242.x

Fritz, U., Auer, M., Bertolero, A., Cheylan, M., Fattizzo, T., Hundsörfer, A. K., Martín Sampayo, M., Pretus, J. L., Široký, P. & Wink, M. (2006). A rangewide phylogeography of Hermann's tortoise, *Testudo hermanni* (Reptilia: Testudines: Testudinidae): implications for taxonomy. — *Zoologica Scripta*, 35, 531–543.

Hermann's tortoise (*Testudo hermanni*), the best-known western Palearctic tortoise species, has a rare natural distribution pattern comprising the Mediterranean areas of the Iberian, Apennine, and Balkan Peninsulas, as well as Sicily, Corsica and Sardinia. The western part of this range is traditionally considered habitat for *T. b. hermanni*, while *T. b. boettgeri* occurs in the Balkans. Taxonomy of this tortoise has been challenged in recent years, with the two subspecies being considered full species and the central Dalmatian populations of *T. b. boettgeri* being considered a third species, *T. hercegovinensis*. Using an mtDNA fragment approximately 1150 bp long (cytochrome *b* gene and adjacent portion of tRNA-Thr gene), we investigated mtDNA diversity with regard to contrasting concepts of two subspecies or three species. Seven closely related haplotypes were identified from the western Mediterranean and 15 different, in part much-differentiated, haplotypes from the Balkans. Western Mediterranean haplotypes differ from Balkan haplotypes in 16–42 mutation steps. One to seven mutation steps occur within western Mediterranean populations. Balkan haplotypes, differing in 1–37 nucleotides, group in parsimony network analysis into three major assemblages that display, in part, a similar degree of differentiation to that of western Mediterranean haplotypes relative to Balkan haplotypes. Rates of sequence evolution are different in both regions, and low divergence, palaeogeography and the fossil record suggest a slower molecular clock in the western Mediterranean. While monophyly in western Mediterranean haplotypes is well-supported, conflicting evidence is obtained for Balkan haplotypes; maximum parsimony supports monophyly of Balkan haplotypes, but other phylogenetic analyses (Bayesian, ML, ME) indicate Balkan haplotypes could be paraphyletic with respect to the western Mediterranean clade. These results imply a process of differentiation not yet complete despite allopatry in the western Mediterranean and the Balkans, and suggest all populations of *T. hermanni* are conspecific. In the western Mediterranean no clear geographical pattern in haplotype distribution is found. Distribution of Balkan haplotypes is more structured. One group of similar haplotypes occurs in the eastern Balkans (Bulgaria, Republic of Macedonia, Romania and the Greek regions Evvia, Macedonia, Peloponnese, Thessaly and Thrace). Two distinct haplotypes, differing in eight to nine mutation steps from the most common haplotype of the first group, are confined to the western slope of the Taygetos Mts. in the Peloponnese. Yet another group, connected over between four and 23 mutation steps with haplotypes of the eastern Balkan group, occurs along the western slope of the Dinarid and Pindos Mts. (Istria, Dalmatia, western Greece). Taygetos haplotypes are nested within other haplotypes in all phylogenetic analyses and support for monophyly of the other Balkan groups is at best weak. We conclude that using the traditional two subspecies model should be continued for *T. hermanni*. Phylogeographies of *T. hermanni* and *Emys orbicularis*, another codistributed chelonian, are markedly different, but share a few similarities. Both were forced to retreat to southern refuges during Pleistocene glaciations. With the advent of Holocene warming, *E. orbicularis* underwent rapid range expansion and temperate regions of Europe and adjacent Asia were recolonized from refuges in the Balkans and the northern Black Sea Region. By contrast, *T. hermanni* remained more

or less confined to refuges and nearby regions, resulting in a much smaller range, and allopatric and parapatric distribution of haplotype groups and clades. MtDNA lineages are more diverse in *E. orbicularis* than they are in *T. bermanni* on southern European peninsulas, indicating several distinct glacial refuges in close proximity and extensive intergradation during Holocene range expansion for *E. orbicularis*. In *T. bermanni* it is likely that only on the Balkan Peninsula was more than one refuge located, corresponding to the parapatric ranges of haplotype groups currently there. On the old western Mediterranean islands Corsica and Sardinia no differentiated (*E. orbicularis*) or only weakly differentiated haplotypes (*T. bermanni*) occur, even though there is evidence for the presence of both species on Corsica since at least the Middle Pleistocene. High mountain chains constitute major barriers separating distinct mtDNA clades or groups in each species.

Uwe Fritz, Markus Auer, Anna K. Hundsdoerfer, Museum of Zoology (Museum für Tierkunde), Natural History State Collections Dresden, Königsbrücker Landstr. 159, D-01109 Dresden, Germany. E-mail: uwe.fritz@snsd.smrwk.sachsen.de, markus.auer@snsd.smrwk.sachsen.de, anna.bundsdoerfer@snsd.smrwk.sachsen.de

Albert Bertolero, Marc Cheylan, Laboratoire de Biogéographie et Écologie des Vertébrés, EPHE — case 94, UM2 Place Eugène Bataillon, F-34095 Montpellier cedex 05, France. E-mail: abertolero@univ-montp2.fr, cheylan@univ-montp2.fr

Tiziano Fattizzo, Museo Civico 'P. Parenzan', Via S. Margherita, 91, I-72022 Latiano, Italy. E-mail: tfattizzo@yahoo.it

Marcos Martín Sampayo, Joan L. Pretus, Departament d'Ecologia, Facultat de Biologia, Universitat de Barcelona, Diagonal 645, E-08028 Barcelona, Spain. E-mail: martinsampayo@ub.edu, jpretus@ub.edu

Pavel Šíroky, Department of Biology and Wildlife Diseases, Faculty of Veterinary Hygiene and Ecology, University of Veterinary and Pharmaceutical Sciences, Palackého 1-3, CZ-612 42 Brno, Czech Republic. E-mail: srokyp@vfu.cz

Michael Wink, Institute of Pharmacy and Molecular Biotechnology, Heidelberg University, INF 364, D-69120 Heidelberg, Germany. E-mail: wink@uni-hd.de

Introduction

The small to medium-sized Hermann's tortoise (*Testudo bermanni* Gmelin, 1789), one of five western Palaearctic species of true tortoises (Testudinidae; Fritz & Cheylan 2001), is distributed over the northern Mediterranean region. It inhabits a patchy area with isolated ranges in continental Spain, France and Italy, and on Mallorca and Menorca (Balearic Islands), Corsica, Sardinia and Sicily. In the eastern Mediterranean, Hermann's tortoise is distributed over most of the Balkan Peninsula while in the western Mediterranean it is confined to areas with a Mediterranean climate. On the Balkan Peninsula, however, it also enters inland regions with more of a continental climatic influence in Bosnia-Herzegovina, Serbia and Montenegro, the Republic of Macedonia, Romania and Bulgaria.

In addition to climate and topography, the species' range has been strongly shaped by human impact and Pleistocene climatic fluctuations. While Balearic populations are thought to have been introduced 3000 years ago, other isolated populations in the western Mediterranean are relicts from an originally continuous Upper Pleistocene and Holocene distribution that stretched from Portugal along the Mediterranean coast to the Apennine Peninsula (Cheylan 2001). Until the tortoise trade was banned in the early 1980s, tens of thousands of Hermann's tortoises were sold annually in the European

pet trade (Groombridge 1982), making it the best-known tortoise in Europe.

Following pioneering work by Wermuth (1952), two subspecies are recognized: *Testudo bermanni bermanni* Gmelin, 1789 occupies the patchy western Mediterranean range and *T. b. boettgeri* Mojsisovics, 1889 occurs in the Balkans. Both differ much in size, coloration and pattern but pronounced population-specific morphological differences also exist within each subspecies. Generally, specimens of *T. b. bermanni* are small (maximum shell length approximately 22 cm), with a contrasting lemon yellow and black colour pattern. *Testudo bermanni boettgeri* reaches a larger size (maximum shell length approximately 36 cm) and exhibits a slightly greenish coloration with a less distinct dark pattern (Cheylan 2001). In recent years, this taxonomy has been challenged and the two subspecies were suggested to be full species while central Dalmatian populations of *T. b. boettgeri*, lacking inguinal scutes, were considered a third species, *T. hercegovinensis* (Perälä 2002, 2004; Bour 2004a,b). These taxonomic changes were not accepted by all authors, however (Fritz *et al.* 2005a; Parham *et al.* 2006), and we adhere provisionally to a more conservative taxonomy in referring to western Mediterranean populations as *T. b. bermanni* and to all Balkan populations as *T. b. boettgeri*. Our underlying species concept is the polytypic Biological Species Concept of Ernst Mayr (1942, 1963; see also Coyne & Orr 2004).

A natural distribution pattern comprising the Mediterranean areas of the Iberian, Apennine, and Balkan Peninsulas, as well as Corsica and Sardinia, as in *T. hermanni*, is rare among reptiles and occurs only in four other wide-ranging species (*Emys orbicularis*, *Hemidactylus turcicus*, *Tarentola mauritanica* and *Natrix natrix*; Arnold 2002). Of these, a rangewide, detailed phylogeography is available only for *E. orbicularis* (Lenk et al. 1999) and no comparable investigation has yet been published for *T. hermanni*. Two previous studies with limited scope used the mitochondrial 12S rRNA gene and found little variation in this slowly evolving gene (van der Kuyl et al. 2002; Mirimin et al. 2004). Based on rangewide sampling, we studied an mtDNA fragment approximately 1150 bp long comprising the cytochrome *b* gene (*cyt b*) and part of the adjacent tRNA-Thr gene. *Cyt b* is known in other testudinid species to have a higher percentage of phylogenetically informative sites than the 12S rRNA gene (Caccone et al. 1999; Palkovacs et al. 2002) and is widely used for phylogenetic and phylogeographical purposes in testudinoid chelonians (e.g. Caccone et al. 1999; Lenk et al. 1999; Feldman & Parham 2002; Palkovacs et al. 2002; Austin et al. 2003; Barth et al. 2004; Fritz et al. 2004, 2005a,b,c; 2006; Mantziou et al. 2004; Spinks et al. 2004).

The goals of our study are: (i) to provide a complete phylogeography for *T. hermanni* using this faster evolving marker;

(ii) to compare phylogeographies of *T. hermanni* and *E. orbicularis*, and (iii) to test whether mtDNA diversity of *T. hermanni* corresponds to the two subspecies concept of Wermuth (1952) or to the more recently suggested partition into three species.

Materials and methods

Sampling

We studied 31 samples of *Testudo hermanni hermanni* and 56 samples of *T. b. boettgeri* (including six '*T. hercegovinensis*') from localities covering the entire species' range (Fig. 1; Table 1). A few samples served as outgroups in a previous paper (AJ888357–64; Fritz et al. 2005a). Blood samples were obtained by coccygeal vein puncture of wild or captive individuals. Alternatively, muscle tissue was extracted from thighs of frozen carcasses prior to alcohol preservation. Samples were either preserved in an EDTA buffer (0.1 M Tris, pH 7.4, 10% EDTA, 1% NaF, 0.1% thymol) or in ethanol, and stored at -20°C until processing. Remaining blood, tissue, and DNA samples are permanently kept at -80°C in the blood and tissue sample collection of the Museum of Zoology, Dresden.

DNA isolation, PCR and sequencing

Total genomic DNA was extracted from samples by overnight incubation at 37°C in lysis buffer (10 mM Tris, pH 7.5, 25 mM EDTA, 75 mM NaCl, 1% SDS) including 1 mg of proteinase

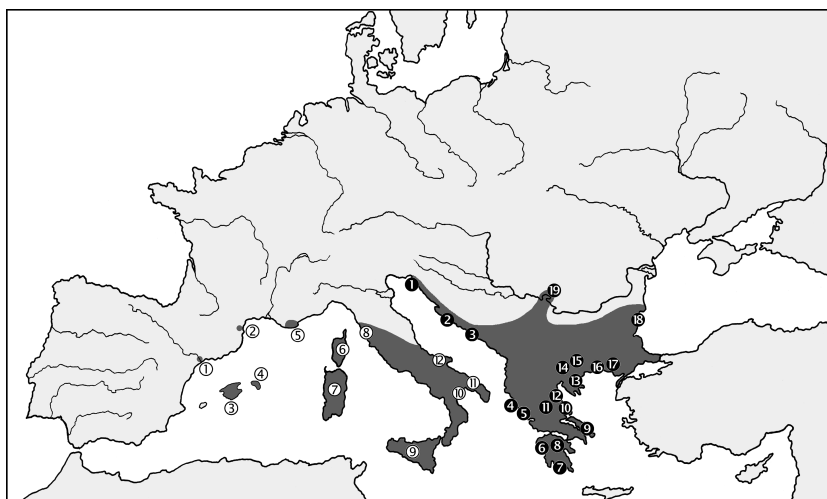

Fig. 1 Range (shaded) and collection sites (numbers) of *Testudo hermanni*. Neighbouring localities combined (see Table 1 for exact sites). *Testudo hermanni hermanni* (open circles): (1) Ebro Delta, Spain; (2) Albera, Spain; (3) Mallorca, Spain; (4) Menorca, Spain; (5) Département Var, France (type locality of *T. b. hermanni*); (6) Corsica, France; (7) Sardinia, Italy; (8) Tuscany, Italy; (9) Sicily, Italy; (10) Basilicata, Italy; (11) southern Apulia, Italy; (12) Mt. Gargano, Apulia, Italy. *Testudo hermanni boettgeri* (black circles): (1) Istria, Croatia; (2) central Dalmatia, Croatia; (3) Pelješac Peninsula, Dalmatia, Croatia; (4) Corfu, Greece; (5) Epirus, Greece; (6) north-western Peloponnese, Greece; (7) southern Peloponnese, Greece; (8) northern Peloponnese, Greece; (9) Evvia, Greece; (10) Volos, Thessaly, Greece; (11) Monasteries of Meteora, Thessaly, Greece; (12) Mt. Olympus Region, Macedonia, Greece; (13) Macedonia, Greece; (14) southern Republic of Macedonia; (15) south-western Bulgaria; (16) and (17) Thrace, Greece; (18) north-eastern Bulgaria; (19) Banat, Romania (type locality of *T. b. boettgeri*). According to Perälä (2002), localities (2) and (3) lie in the range of '*Testudo hercegovinensis*'. In north-eastern Italy exist isolated populations of *T. hermanni* (not shown) that are likely to be introduced (Cheylan 2001).

Table 1 Studied *Testudo hermanni* samples.

Taxon	Site	Exact locality	Haplotype	MTD	Accession number
<i>Testudo hermanni hermanni</i>	1	Spain: Ebro Delta; 40°42'N 0°43'E	H3	T 1956	AM230495
<i>Testudo hermanni hermanni</i>	1	Spain: Ebro Delta; 40°42'N 0°43'E	H5	T 1960	AM230496
<i>Testudo hermanni hermanni</i>	2	Spain: Albera; 42°22'N 02°57'E	H3	T 1914	AM230497
<i>Testudo hermanni hermanni</i>	2	Spain: Albera; 42°22'N 02°57'E	H3	T 1918	AM230498
<i>Testudo hermanni hermanni</i>	3	Spain: Mallorca: Son Real; 39°46'N 03°07'E	H3	T 1962	AM230499
<i>Testudo hermanni hermanni</i>	3	Spain: Mallorca: Son Real; 39°46'N 03°07'E	H3	T 1963	AM230500
<i>Testudo hermanni hermanni</i>	4	Spain: Menorca: Bec; 39°56'N 04°03'E	H5	T 1946	AM230501
<i>Testudo hermanni hermanni</i>	4	Spain: Menorca: Pilar; 40°04'N 03°59'E	H3	T 1952	AM230502
<i>Testudo hermanni hermanni</i>	4	Spain: Menorca: Tirant; 40°04'N 04°06'E	H3	T 1938	AM230503
<i>Testudo hermanni hermanni</i>	5	France: Saint-Tropez; 43°16'N 06°38'E	H1	T 1970	AM230504
<i>Testudo hermanni hermanni</i>	5	France: Saint-Tropez; 43°16'N 06°38'E	H1	T 1974	AM230505
<i>Testudo hermanni hermanni</i>	6	France: Corsica: Casabianda; 42°05'N 09°30'E	H5	T 1926	AM230506
<i>Testudo hermanni hermanni</i>	6	France: Corsica: Fontane du Salario (Ajaccio); 41°55'N 08°44'E	H5	T 1932	AM230507
<i>Testudo hermanni hermanni</i>	6	France: Corsica: Porto Vecchio; 41°36'N 09°17'E	H6	T 1920	AM230508
<i>Testudo hermanni hermanni</i>	7	Italy: Sardinia: Alghero; 40°37'N 08°20'E	H5	T 967	AM230509
<i>Testudo hermanni hermanni</i>	7	Italy: Sardinia: Bay of Porto Ferro; 40°41'N 08°12'E	H7	T 1115	AJ888361
<i>Testudo hermanni hermanni</i>	7	Italy: Sardinia: Porto Palmas; 40°46'N 08°10'E	H5	T 1114	AM230510
<i>Testudo hermanni hermanni</i>	8	Italy: Toscana: Piombino; 42°57'N 10°33'E	H1	T 1998	AM230511
<i>Testudo hermanni hermanni</i>	8	Italy: Toscana: Roccatederighi; 43°02'N 11°05'E	H1	D 41590	AJ888362
<i>Testudo hermanni hermanni</i>	8	Italy: Toscana: Roccatederighi; 43°02'N 11°05'E	H4	T 676	AJ888363
<i>Testudo hermanni hermanni</i>	9	Italy: Sicily: Balestrate; 38°03'N 13°00'E	H5	T 2141	AM230512
<i>Testudo hermanni hermanni</i>	9	Italy: Sicily: Castellamare del Golfo; 38°02'N 12°53'E	H5	T 2140	AM230513
<i>Testudo hermanni hermanni</i>	10	Italy: Basilicata: Bosco Pantano di Policoro; 40°12'N 16°41'E	H1	T 1903	AM230514
<i>Testudo hermanni hermanni</i>	11	Italy: Apulia: Ginos Marina; 40°26'N 16°53'E	H2	T 1902	AM230515
<i>Testudo hermanni hermanni</i>	11	Italy: Apulia: Martina Franca; 40°42'N 17°20'E	H1	T 1712	AM230516
<i>Testudo hermanni hermanni</i>	11	Italy: Apulia: Ostuni — San Biagio; 40°44'N 17°35'E	H1	T 1713	AM230517
<i>Testudo hermanni hermanni</i>	11	Italy: Apulia: Ostuni — San Biagio; 40°44'N 17°35'E	H1	T 1988	AM230518
<i>Testudo hermanni hermanni</i>	11	Italy: Apulia: Pianelle; 40°39'N 17°13'E	H1	T 1714	AM230519
<i>Testudo hermanni hermanni</i>	11	Italy: Apulia: Pianelle; 40°39'N 17°13'E	H1	T 1715	AM230520
<i>Testudo hermanni hermanni</i>	12	Italy: Apulia: Mt. Gargano; 41°44'N 15°47'E	H1	T 1711	AM230521
<i>Testudo hermanni hermanni</i>	?	South Italy	H1	D 42972	AJ888364
<i>Testudo hermanni boettgeri</i>	1	Croatia: Istria: Sribanj; 45°21'N 13°38'E	B13	T 2521	AM230522
<i>Testudo hermanni boettgeri</i>	1	Croatia: Istria: Sribanj; 45°21'N 13°38'E	B13	T 2522	AM230523
<i>Testudo hermanni boettgeri</i>	2	Croatia: Dalmatia: Lozovac; 43°48'N 15°58'E	B13	T 2523	AM230524
<i>Testudo hermanni boettgeri</i> (<i>Testudo hercegovinensis</i>)	2	Croatia: Dalmatia: Šibenik; 43°45'N 15°54'E	B13	T 1359	AM230525
<i>Testudo hermanni boettgeri</i> (<i>Testudo hercegovinensis</i>)	3	Croatia: Dalmatia: Pelješac Peninsula: Žuljana; 42°54'N 17°27'E	B13	T 1549	AM230526
<i>Testudo hermanni boettgeri</i> (<i>Testudo hercegovinensis</i>)	3	Croatia: Dalmatia: Pelješac Peninsula: Žuljana; 42°54'N 17°27'E	B13	T 1550	AM230527
<i>Testudo hermanni boettgeri</i> (<i>Testudo hercegovinensis</i>)	3	Croatia: Dalmatia: Pelješac Peninsula: Žuljana; 42°54'N 17°27'E	B13	T 1552	AM230528
<i>Testudo hermanni boettgeri</i> (<i>Testudo hercegovinensis</i>)	3	Croatia: Dalmatia: Pelješac Peninsula: Žuljana; 42°54'N 17°27'E	B13	T 1564	AM230529
<i>Testudo hermanni boettgeri</i>	4	Greece: Corfu: Great Salt Lake; 39°47'15"N 19°55'10"E, 10 m a.s.l.	B12	T 154	AM230530
<i>Testudo hermanni boettgeri</i>	5	Greece: Epirus: Lake Parga; 39°20'29"N 20°26'14"E, 138 m a.s.l.	B10	T 152	AM230572
<i>Testudo hermanni boettgeri</i>	5	Greece: Epirus: Lake Parga; 39°20'29"N 20°26'14"E, 138 m a.s.l.	B11	T 153	AM230573
<i>Testudo hermanni boettgeri</i>	5	Greece: Epirus: Parga; 39°18'N 20°24'E	B15	T 1372	AJ888357
<i>Testudo hermanni boettgeri</i>	5	Greece: Epirus: Parga; 39°18'N 20°24'E	B14	T 1373	AJ888358
<i>Testudo hermanni boettgeri</i>	6	Greece: Peloponnese: Olympia; 37°39'N 21°32'E	B3	T 1544	AM230531
<i>Testudo hermanni boettgeri</i>	6	Greece: Peloponnese: Olympia; 37°39'N 21°32'E	B1	T 1545	AM230532
<i>Testudo hermanni boettgeri</i>	6	Greece: Peloponnese: Olympia; 37°39'N 21°32'E	B1	T 1546	AM230533
<i>Testudo hermanni boettgeri</i>	6	Greece: Peloponnese: Olympia; 37°39'N 21°32'E	B1	T 1547	AM230534
<i>Testudo hermanni boettgeri</i>	7	Greece: Peloponnese: E Saidhona; 36°53'04"N 22°17'20"E, 768 m a.s.l.	B8	T 2372	AM230535
<i>Testudo hermanni boettgeri</i>	7	Greece: Peloponnese: E Saidhona; 36°53'04"N 22°17'34"E, 750 m a.s.l.	B9	T 2371	AM230536
<i>Testudo hermanni boettgeri</i>	7	Greece: Peloponnese: Mistras; 37°04'N 22°22'E	B1	T 1542	AM230537

Table 1 Continued

Taxon	Site	Exact locality	Haplotype	MTD	Accession number
<i>Testudo hermanni boettgeri</i>	7	Greece: Peloponnese: Sparti; 37°05'N 22°26'E	B1	T 1639	AM230538
<i>Testudo hermanni boettgeri</i>	7	Greece: Peloponnese: Sparti; 37°05'N 22°26'E	B1	T 1640	AM230539
<i>Testudo hermanni boettgeri</i>	8	Greece: Peloponnese: between Kalyvia and Arch. Feneos; 37°54'46"N 22°18'35"E, 769 m a.s.l.	B1	T 2375	AM230540
<i>Testudo hermanni boettgeri</i>	8	Greece: Peloponnese: between Kalyvia and Arch. Feneos; 37°54'46"N 22°18'35"E, 769 m a.s.l.	B1	T 2376	AM230541
<i>Testudo hermanni boettgeri</i>	8	Greece: Peloponnese: between Kalyvia and Arch. Feneos; 37°54'46"N 22°18'35"E, 769 m a.s.l.	B1	T 2379	AM230542
<i>Testudo hermanni boettgeri</i>	8	Greece: Peloponnese: between Kalyvia and Arch. Feneos; 37°54'46"N 22°18'35"E, 769 m a.s.l.	B1	T 2381	AM230543
<i>Testudo hermanni boettgeri</i>	9	Greece: Evvia: NW Lake Distos; 38°23'06"N 24°08'21"E, 148 m a.s.l.	B2	T 2356	AM230544
<i>Testudo hermanni boettgeri</i>	9	Greece: Evvia: NW Lake Distos; 38°23'06"N 24°08'21"E, 148 m a.s.l.	B2	T 2359	AM230545
<i>Testudo hermanni boettgeri</i>	9	Greece: Evvia: NW Lake Distos; 38°23'06"N 24°08'21"E, 148 m a.s.l.	B2	T 2361	AM230546
<i>Testudo hermanni boettgeri</i>	10	Greece: Thessaly: Volos; 39°22'N 22°56'E	B1	T 1534	AM230548
<i>Testudo hermanni boettgeri</i>	10	Greece: Thessaly: Volos; 39°22'N 22°56'E	B1	T 1535	AM230549
<i>Testudo hermanni boettgeri</i>	11	Greece: Thessaly: Monasteries of Meteora; 39°44'N 21°38'E	B1	T 1401	AM230550
<i>Testudo hermanni boettgeri</i>	12	Greece: Macedonia: Leptokaria; 40°03'N 22°31'E	B4	T 1369	AM230551
<i>Testudo hermanni boettgeri</i>	12	Greece: Macedonia: Leptokaria; 40°03'N 22°31'E	B1	T 1641	AM230552
<i>Testudo hermanni boettgeri</i>	12	Greece: Macedonia: Mt. Olympus; 40°27'N 21°27'E	B6	T 389	AM230553
<i>Testudo hermanni boettgeri</i>	12	Greece: Macedonia: Mt. Olympus; 40°27'N 21°27'E	B6	T 390	AM230554
<i>Testudo hermanni boettgeri</i>	12	Greece: Macedonia: Mt. Olympus; 40°27'N 21°27'E	B7	T 391	AJ888359
<i>Testudo hermanni boettgeri</i>	12	Greece: Macedonia: Platamonas; 39°58'N 22°33'E	B5	T 1370	AJ888360
<i>Testudo hermanni boettgeri</i>	13	Greece: Macedonia: Stavros; 40°40'N 23°42'E	B1	T 1371	AM230547
<i>Testudo hermanni boettgeri</i>	14	Republic of Macedonia: Gradsko; 41°25'N 22°40'E	B1	T 1397	AM230555
<i>Testudo hermanni boettgeri</i>	14	Republic of Macedonia: Gradsko; 41°25'N 22°40'E	B1	T 1398	AM230556
<i>Testudo hermanni boettgeri</i>	15	Bulgaria: Pirin; 41°33'N 23°34'E	B1	T 2308	AM230557
<i>Testudo hermanni boettgeri</i>	15	Bulgaria: W Pirin; 41°32'12"N 23°32'19"E, 778 m a.s.l.	B1	T 1364	AM230558
<i>Testudo hermanni boettgeri</i>	15	Bulgaria: SW Kašina; 41°33'00"N 23°27'33"E, 710 m a.s.l.	B1	T 1366	AM230559
<i>Testudo hermanni boettgeri</i>	16	Greece: Macedonia: Nestos Delta, SE Hrissooupoli; 40°58'N 24°43'E	B1	T 1619	AM230560
<i>Testudo hermanni boettgeri</i>	16	Greece: Macedonia: Nestos Delta, SE Hrissooupoli; 40°58'N 24°43'E	B1	T 1620	AM230561
<i>Testudo hermanni boettgeri</i>	16	Greece: Thrace: 10 km S Livaditis; 41°15'N 24°41'E	B1	T 1617	AM230562
<i>Testudo hermanni boettgeri</i>	16	Greece: Thrace: between Stavroupoli and Kerokamos; 41°12'N 24°44'E	B1	T 1618	AM230563
<i>Testudo hermanni boettgeri</i>	17	Bulgaria: Kukuryak; 41°19'N 25°27'E	B1	T 2314	AM230564
<i>Testudo hermanni boettgeri</i>	17	Bulgaria: Kukuryak; 41°19'N 25°27'E	B1	T 2321	AM230565
<i>Testudo hermanni boettgeri</i>	17	Greece: Thrace: Evros Delta, approx. 25 km E Alexandroupoli; 40°52'N 25°36'E	B1	T 1621	AM230566
<i>Testudo hermanni boettgeri</i>	18	Bulgaria: Albena; 43°22'27"N 28°05'66"E, 106 m a.s.l.	B6	T 726	AM230567
<i>Testudo hermanni boettgeri</i>	18	Bulgaria: Albena; 43°22'28"N 28°05'07"E, 109 m a.s.l.	B1	T 729	AM230568
<i>Testudo hermanni boettgeri</i>	19	Romania: Banat; approx. 44°50'N 22°25'E	B1	T 2537	AM230569
<i>Testudo hermanni boettgeri</i>	19	Romania: Banat; approx. 44°50'N 22°25'E	B1	T 2538	AM230570
<i>Testudo hermanni boettgeri</i>	19	Romania: Banat; approx. 44°50'N 22°25'E	B1	T 2539	AM230571

Sites refer to Fig. 1. MTD D numbers refer to complete voucher specimens, MTD T numbers to blood, tissue or DNA samples in the collection of the Museum of Zoology, Dresden. Provisional HD numbers of samples studied by Fritz *et al.* (2005a) replaced by permanent MTD numbers.

K (Roth or Merck), followed by either the DTAB method (Gustincich *et al.* 1991) or a standard phenol/chloroform protein extraction (Sambrook *et al.* 1989). DNA was precipitated from the supernatant with 0.8 volumes of cold isopropanol, centrifuged, washed, dried and resuspended in TE buffer. A fragment comprising almost the complete *cyt b* gene and the adjacent portion of the *tRNA-Thr* gene was amplified using PCR primers listed in Table 2.

PCR was performed in a 50 μ L volume (Bioron PCR buffer or 50 mM KCl, 1.5 mM MgCl₂, and 10 mM Tris-HCl, 0.5% Triton X-100, pH 8.5) containing 1 unit of *Taq* DNA polymerase (Bioron), 10 pmol dNTPs (Fermentas) and 5 or 10 pmol of each primer. After initial denaturing for 5 min at 94 °C, 35–40 cycles were performed with denaturing 45 s at 94 °C, annealing 52 s

at 55–60 °C, and primer extension for 80 s at 72 °C, followed by a final elongation of 10 min at 72 °C. Alternatively, 4 min initial denaturation at 94 °C was followed by 30 cycles of 45 s at 94 °C, 60 s at 52 °C and 120 s at 72 °C with final elongation of 10 min at 72 °C.

PCR products were purified by precipitation under the following conditions: 1 volume PCR product (30 μ L), 1 volume 4 M NH₄Ac (30 μ L) and 12 volumes EtOH (100%; 360 μ L). DNA was pelleted by centrifugation (15 min at 13 000 rpm) and the pellet washed with 70% ethanol. The pellet was dissolved in 20 μ L H₂O. PCR products were sequenced directly on both strands on ABI or MegaBase 1000 (Amersham Biosciences) sequencers (for internal primers see Table 2). Because no internal stop codons were found and nucleotide frequencies

Primer	Sequence (5' to 3')	Direction
PCR primer		
mt-A1	CCC CCT ACC AAC ATC TCA GCA TGA TGA AAC TTC G	Forward
mt-a-neu	CTC CCA GCC CCA TCC AAC ATC TCA GCA TGA TGA AAC TTC G	Forward
mt-a-neu2	CTC CCA GCC CCA TCC AAC ATC TCA GCA TGA TGA AAC	Forward
mt-f-na	AGG GTG GAG TCT TCA GTT TTT GGT TTA CAA GAC CAA TG	Reverse
mt-Fr	CTA AGA AGG GTG GAG TCT TCA GTT TTT GGT TTA CAA	Reverse
Internal primer		
mt-c2	TGA GGA CAA ATA TCA TTC TGA GG	Forward
mt-c-For2	TGA GGV CAR ATA TCA TTY TGA G	Forward
mt-E-Rev	GCA AAT AGG AAG TAT CAT TCT GG	Reverse
mt-E-Rev2	GCR AAT ARR AAG TAT CAT TCT GG	Reverse

Table 2 Primers used in this study.

corresponded to those known for coding mtDNA, we conclude that we amplified and sequenced mtDNA and not nuclear copies of mitochondrial genes.

Phylogenetic analyses

The 87 ingroup sequences obtained were collapsed to 22 haplotypes (Table 1), which were analysed by heuristic searches with PAUP* 4.0b10 (Swofford 2002) using 'tree-bisection-reconnection' (TBR) branch swapping under the optimality criteria minimum evolution (ME; ML-corrected distances), maximum likelihood (ML; stepwise addition), and maximum parsimony (MP; setting add = cl). For ingroup species, 1054 of 1134 aligned sites were constant, 32 characters were variable but parsimony-uninformative, and 48 variable characters were parsimony-informative. The best evolutionary model was established as HKY + G by hierarchical likelihood testing, performed with MODELTEST 3.06 (Posada & Crandall 1998); model parameters: base = 0.3048 (A), 0.3040 (C), 0.1179 (G); TRatio = 3.4282; gamma shape parameter = 0.6765. Bootstrap permutations (Felsenstein 1985) were run to test robustness of obtained branching patterns under optimality criteria ME (nreps = 1000), ML (settings maxtrees = 10, nreps = 100), and MP (maxtrees = 1000, nreps = 1000).

To determine whether sequence evolution is clockwise, we performed a likelihood ratio test (Swofford *et al.* 1996) for likelihood scores of ML trees with and without an enforced molecular clock for (i) all ingroup haplotypes and outgroup sequences, (ii) only for ingroup haplotypes, and (iii) for *Testudo bermanni bermanni* and *T. b. boettgeri* haplotypes separately. As the likelihood ratio test could incorrectly indicate different rates when comparing sequences of different lengths, we used a completely overlapping, pruned alignment of 700 bp length. Bayesian analysis was performed with MRBAYES 3.1 (Huelsenbeck & Ronquist 2001), whereby the settings were four chains of 1 000 000 generations sampling every 100 and a burn-in of 500 (with which only the plateau of the most likely trees was sampled). We included in all analyses as outgroups two earlier published sequences of *Testudo horsfieldii*

(*T. b. kazachstanica*, AJ888365 and *T. b. rustamovi*, AJ888366; Fritz *et al.* 2005a), representing a species distantly related to *T. bermanni* and all other western Palaearctic *Testudo* species (Fritz *et al.* 2005a; Parham *et al.* 2006). Genetic distances (uncorrected *p*-distances; ML distances without outgroups) were estimated using PAUP*.

In addition, we calculated a haplotype network with TCS 1.21 (Clement *et al.* 2000) for all sequences because intraspecific data cannot always be represented by dichotomous trees. This software is based on statistical parsimony for constructing a haplotype network in that the required number of mutational steps leading from one haplotype to another is minimized. In contrast to dichotomous phylogenetic trees, networks allow for persistent ancestral nodes and reticulations. Such a network is able to demonstrate simultaneous alternative evolutionary pathways, with occurrence of reticulations visualizing ambiguous or uncertain domains. In haplotypic data, loops can also indicate reverse or parallel mutations (Posada & Crandall 2001).

Results

Haplotype diversity, sequence evolution rates and phylogeny

Average nucleotide composition of the sequenced DNA stretch was as follows: T = 28.0%, C = 29.6%, A = 30.7%, G = 11.7%. We found seven haplotypes within *Testudo bermanni bermanni*, differing in 1–7 mutation steps, and a much higher diversity within *T. b. boettgeri*. In the latter, we discovered 15 other haplotypes, differing in 1–37 nucleotides. Haplotypes of both subspecies differ in 16–42 mutation steps. Average uncorrected *p*-distance within haplotypes of *T. bermanni* is 1.48% (range: 0.09–4.51%), within haplotypes of *T. b. bermanni* 0.31% (0.09–0.56%), and within haplotypes of *T. b. boettgeri* 1.16% (0.09–3.21%). Average ML distance for *T. bermanni* haplotypes is 1.63% (0.08–5.26%), *T. b. bermanni* haplotypes, 0.31% (0.08–0.60%), and *T. b. boettgeri* haplotypes, 1.25% (0.09–3.61%).

While *T. b. bermanni* haplotypes form a well-supported clade under all tree-building methods, monophyly of *T. b. boettgeri* haplotypes is questionable (Figs 2, 3). Only MP yields a

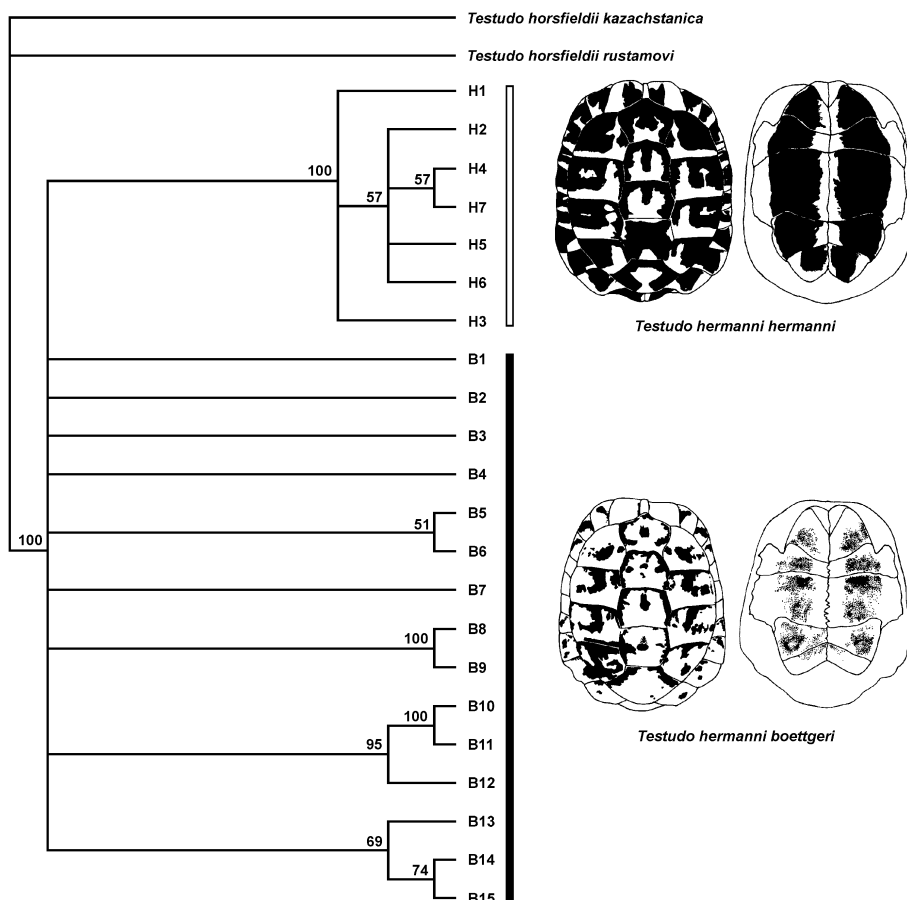

Fig. 2 ME 50% bootstrap majority-rule consensus tree of *Testudo hermanni* mtDNA haplotypes. Haplotypes H1–H7 correspond to *T. b. hermanni*, B1–B15, *T. b. boettgeri*. Numbers at nodes represent bootstrap values (1000 replicates) greater than 50. Right, dorsal and ventral aspect of shell.

moderately high bootstrap support of 84 for a clade consisting of all *T. b. boettgeri* haplotypes. Under ME, ML and Bayesian analyses the monophyletic *T. b. hermanni* haplotypes (100% bootstrap and posterior probability support) are nested within *T. b. boettgeri*. ML and Bayesian analyses result in a weakly supported sister group relationship of *T. b. hermanni* haplotypes and *T. b. boettgeri* haplotypes B10–B15. This clade is nested within the other *T. b. boettgeri* haplotypes. Under ME, the *T. b. hermanni* clade and *T. b. boettgeri* haplotypes branch off in a polytomy.

The likelihood ratio test indicated that sequence evolution rates are homogeneous only within haplotypes of the same subspecies. Substitution rates varied significantly between branches when comparing all ingroup or ingroup and outgroup haplotypes.

In the network, *T. b. hermanni* haplotypes appear as a distinct, compact subnet, while *T. b. boettgeri* haplotypes do not form a clear-cut subunit (Fig. 4). Instead, *T. b. boettgeri* haplotypes

group into three major assemblages that display, in part, a similar degree of differentiation to that of *T. b. hermanni* haplotypes relative to *T. b. boettgeri*. However, with the exception of the very similar B8 and B9 haplotypes, monophyly of these haplotype clusters of *T. b. boettgeri* is not, or only weakly, supported in phylogenetic analyses, and B8 and B9 are nested within other haplotypes in all phylogenetic analyses (Figs 2, 3). Two loops occur, one within *T. b. hermanni* haplotypes, and the other within *T. b. boettgeri* haplotypes from the eastern Balkans.

Geographic distribution of haplotypes

We found only a weak and obscured geographical structure in haplotypes of *Testudo hermanni hermanni* (Fig. 5). The most common haplotype, H1, detected in 12 of 31 samples, occurs in southern Italy, Tuscany and southern France. Haplotype H5 ($n = 8$), differing in two or three mutation steps from H1, occurs in the Ebro Delta, on Menorca, Sicily,

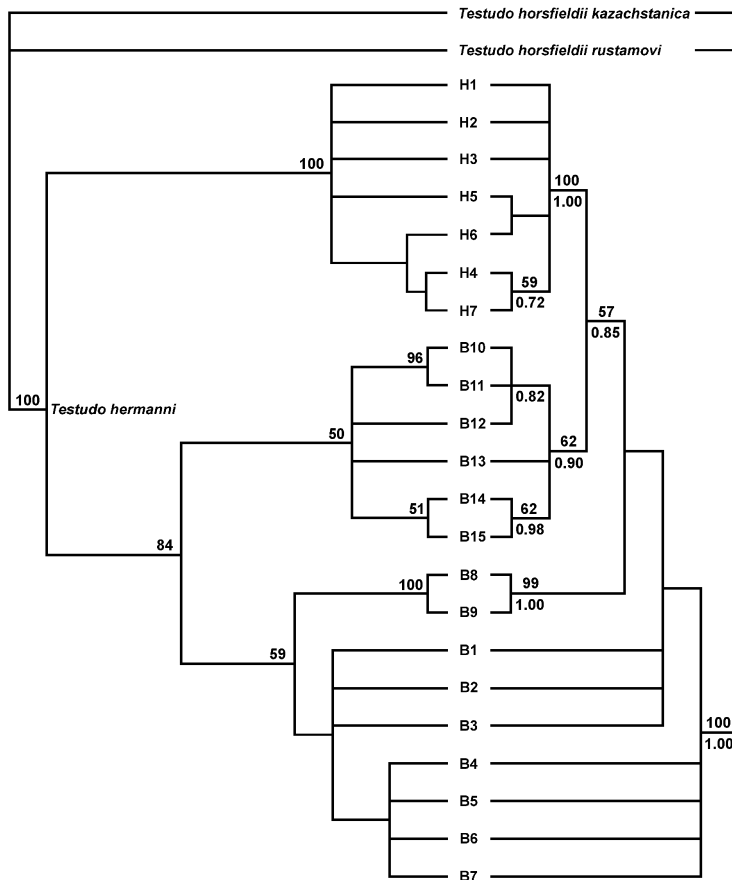

Fig. 3 Left, MP 50% majority-rule consensus of 7958 parsimony trees (CI = 0.9336, RI = 0.9472; 211 steps); right, ML 50% majority-rule consensus of 36 trees of *Testudo hermanni* mtDNA haplotypes. Haplotypes H1–H7 correspond to *T. b. hermanni*, B1–B15, *T. b. boettgeri*. Left, numbers above nodes are MP bootstrap values (1000 replicates) equal to or greater than 50. Right, numbers above nodes are ML bootstrap values (100 replicates) greater than 50; numbers below nodes represent posterior probabilities greater than 0.70 when the respective branch was discovered under Bayesian analysis.

Corsica and Sardinia. Closely related haplotypes H6 and H7 were detected in one tortoise each from Corsica and Sardinia, respectively. Haplotypes H1, H5 and H6 form the loop within the *T. b. hermanni* subnet. Haplotypes H2 and H4, connected only to H1, were found in one tortoise each from southern Italy and Tuscany. H3, differing in one nucleotide from H1, is another rather common haplotype ($n = 7$) that appears to be confined to Spain (Ebro Delta, Albera, Mallorca, Menorca).

Geographic distribution of *T. b. boettgeri* haplotypes is distinctly more structured. One widely distributed group of similar sequences from the eastern Balkans (Bulgaria, Republic of Macedonia, Romania, and the Greek regions Evvia, Macedonia, Peloponnese, Thessaly and Thrace) includes the network loop of *T. b. boettgeri* haplotypes (Figs 4, 5). The most common haplotype, B1, belongs to this group and was found in 31 of 56 *T. b. boettgeri* samples. Besides B1 and its rare variant B3, two quite distinct haplotypes occur on the Peloponnese (B8 and B9), differing in 8–9 mutation steps from B1. Haplotypes B10–B15 are confined to the Adriatic and Ionic coasts (Istria, Dalmatia, western Greece); B10 is connected over four mutation steps with the loop of eastern Balkan haplotypes and occurs in the southernmost locality

for this group (Epirus Region, Greece). In the same region, the much-differentiated haplotypes B14 and B15 also occur, and are connected over 21 and 23 mutation steps with the loop. Intermediate haplotypes B11, B12 and B13 also occur in Epirus, on Corfu and in coastal regions of Istria and Dalmatia (Croatia).

Discussion

We detected more mtDNA sequence variation in *Testudo hermanni* than van der Kuyl *et al.* (2002) and Mirimin *et al.* (2004), who studied the slowly evolving mitochondrial 12S rRNA gene. Van der Kuyl *et al.* (2002) discovered in 40 *T. b. hermanni* only two haplotypes and in nine *T. b. boettgeri* three haplotypes, differing in 1–3 substitutions. A problem of this investigation was that many tortoises of unknown or imprecise provenance were studied. Such specimens cannot be used for assessing geographical variation (Harris *et al.* 2003). After studying 47, probably in part allochthonous, tortoises from Spain and Italy, Mirimin *et al.* (2004) reported four additional 12S rRNA haplotypes, two corresponding to *T. b. hermanni*, and two to *T. b. boettgeri*. Based on rangewide sampling of the more informative *cyt b* gene, we found in

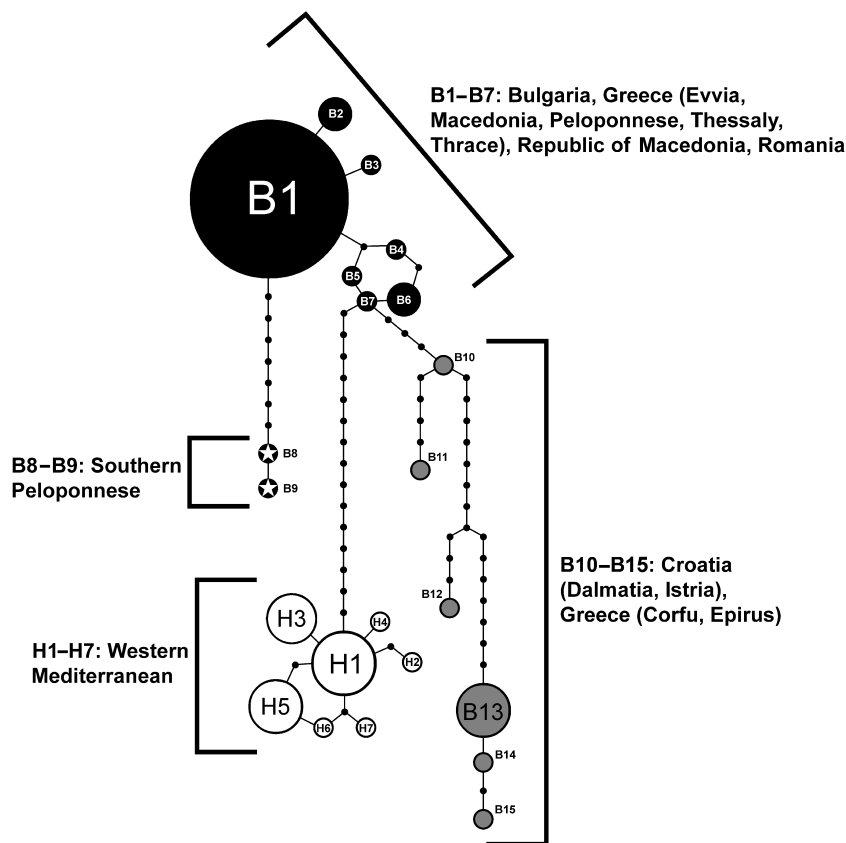

Fig. 4 Parsimony network (TCS) of *Testudo hermanni* mtDNA haplotypes. Haplotypes H1–H7 correspond to *T. b. hermanni* (open circles), B1–B15, *T. b. boettgeri* (dark circles). In *T. b. boettgeri*, solid black circles indicate eastern Balkan haplotype group (B1–B7); black circles with white asterisks, Taygetos haplotypes B8 and B9; dark grey circles, west coast haplotype group (B10–B15). Symbol size corresponds approximately to haplotype frequency. H1: $n = 12$, H3: $n = 7$, H5: $n = 8$, B1: $n = 31$, B2: $n = 3$, B6: $n = 3$, B13: $n = 8$, all other haplotypes: $n = 1$. Small black dots indicate missing haplotypes. Lines between circles or dots correspond to one mutation step.

31 *T. b. hermanni* seven closely related haplotypes and in 56 *T. b. boettgeri* 15 other, in part much-differentiated, haplotypes.

Low differentiation in *T. b. hermanni* haplotypes when compared with *T. b. boettgeri*, as revealed by our data set, was unexpected considering the complicated geological history of the western Mediterranean basin, the age of the Corso-Sardinian archipelago (de Jong 1998; Rögl 1998) and the long-established presence of Hermann's tortoises on Corsica (Middle Pleistocene: Hervet 2000, 2001; Hervet & Salotti 2000). Van der Kuyl *et al.* (2002) attributed low genetic differentiation in western Mediterranean *T. b. hermanni*, also mirrored by our data, to translocation of tortoises by man. Without doubt, this played an important role in some regions as the populations on Mallorca and Menorca are evidently not native. Despite an excellent fossil and archaeological record, the oldest findings in the Balearic Islands date back only to the Neolithic Talayot Culture (3000 years BP; Cheylan 2001). However, the Middle Pleistocene record for Corsica and the numerous fossil and subfossil findings in Sicily and the western Mediterranean mainland regions where *T. b. hermanni* lives today (Hervet 2000, 2001; Hervet & Salotti 2000; Cheylan 2001; Delfino 2002) imply that the current situation in the western Mediterranean cannot be explained by introduction alone.

In recent years tortoises have been released in the Spanish Ebro Delta for population reinforcement (Cheylan 2001). If haplotypes from this locality and the Balearic Islands are excluded from phylogeographical consideration, a vicariant distribution of haplotypes emerges (H3: Spanish Mediterranean coast; H5, H6, H7: Corsica, Sardinia, Sicily; H1, H2, H4: southern France, Apennine Peninsula) that could reflect a natural pattern with much less haplotypic divergence than that for the Balkans. This discrepancy could be correlated with observed differences in sequence evolution rates in western Mediterranean (*T. b. hermanni*) and Balkan haplotypes (*T. b. boettgeri*), suggestive of a slower molecular clock in the western Mediterranean.

Within *T. b. boettgeri* three haplotype groups were identified by parsimony network analysis; one group (B10–B15) is distributed along the west coast of the Balkans. This region is quite isolated by the Dinarid and Pindos mountain chains separating west coast haplotypes B10–B15 from eastern Balkan haplotypes B1–B7. Two other distinct haplotypes, B8 and B9, occur on the also rather isolated western slope of the Taygetos Mts., southern Peloponnese (Mani Peninsula, east of Saidhona, 36°53'N 22°17'E). These haplotypes differ by eight and nine mutation steps, respectively, from the common eastern Balkan haplotype B1 that occurs approximately

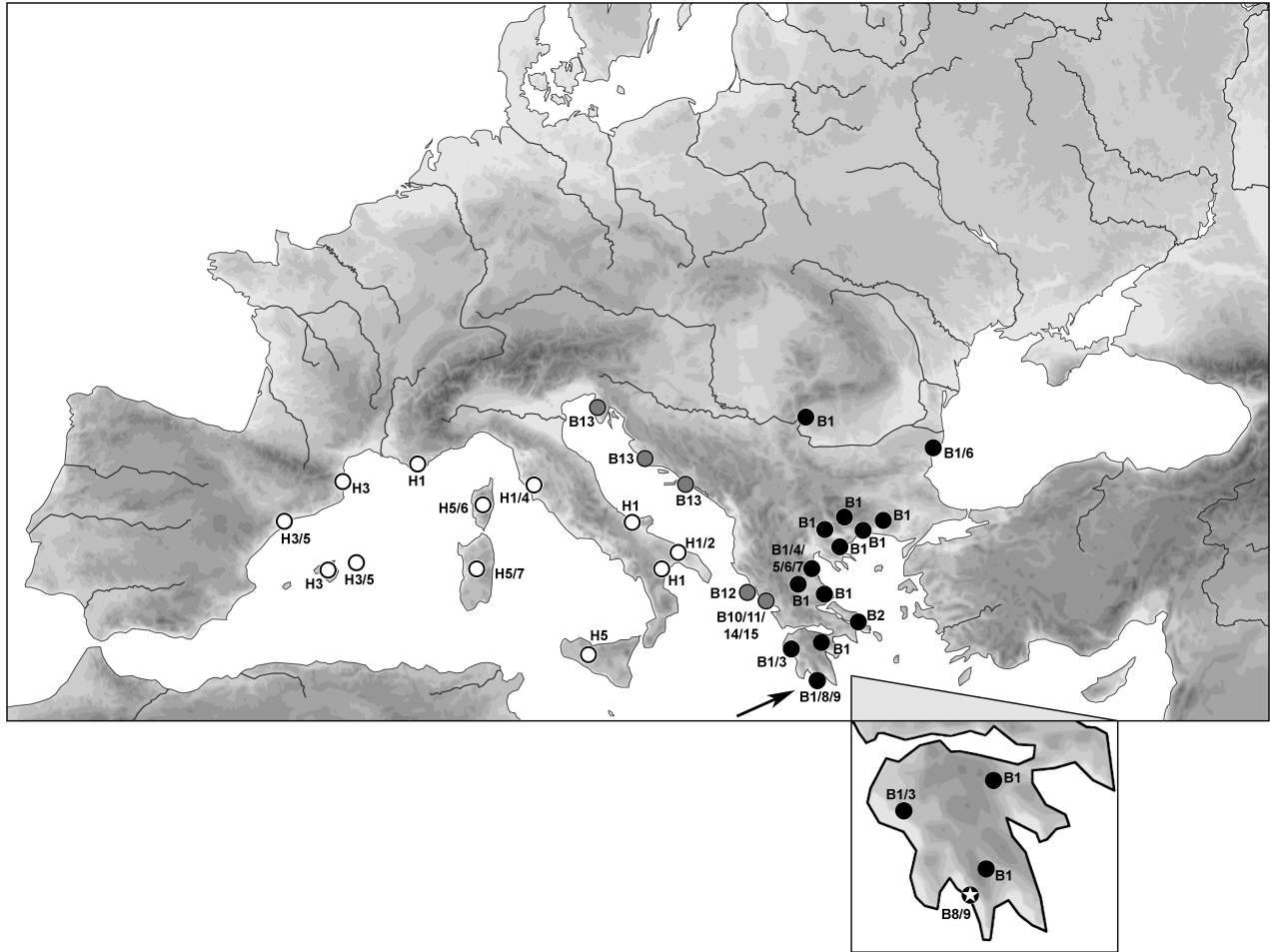

Fig. 5 Distribution of *Testudo hermanni* haplotypes. Shading of mountain ranges increases with elevation. Peloponnese enlarged (bottom, right). *Testudo hermanni hermanni* (open circles); *T. b. boettgeri* (dark circles, symbols for haplotype groups as in Fig. 4). Haplotypes occurring syntopically or in close neighbourhood indicated by slashes between haplotype numbers. Arrow indicates eastern Balkan haplotypes occurring in close proximity to haplotypes B8 and B9 in Taygetos Region (see enlarged map of Peloponnese).

20 km distant on the other side of the Taygetos Mts. (Mistras, 37°04'N 22°22'E; Sparti, 37°05'N 22°26'E). Further sampling is needed to clarify the taxonomic status of this southern Peloponnesian population. Bour (1996, 2004b) reported a few morphologically distinctive characters for Hermann's tortoises from the western slope of the Taygetos Mts., suggesting a certain degree of differentiation.

A morphologically distinctive population of another tortoise species (*T. marginata*) occurs in the same region but differs neither in mtDNA haplotypes nor in nuclear genomic markers from other *T. marginata* populations. Likewise, and in contrast to *T. hermanni*, on both sides of the Pindos Mts. no genetic differentiation was detected in *T. marginata* (Fritz et al. 2005a), suggesting that the Pindos and Taygetos Mts. do not act as barrier to gene flow in this species. This difference between the two tortoise species could be caused by distinct

habitat preferences. *Testudo hermanni* seems to prefer lower elevations (Cheylan 2001), while *T. marginata* is known to reach 1300 m or more (Bringsøe et al. 2001), enabling it to pass or circumvent mountain chains in moderate elevations.

Sampling of recently published phylogeographies of other codistributed southern Balkan reptiles is far too patchy for evaluating the impact of these mountain chains on genetic structuring (*Mauremys rivulata*: Mantziou et al. 2004; *Lacerta trilineata*: Godinho et al. 2005; *Podarcis muralis*, *P. peloponnesiaca*, *P. taurica*: Poulakakis et al. 2005; *Natrix natrix*, *N. tessellata*: Guicking et al. 2006; *Malpolon insignitus*: Carranza et al. 2006). On a larger geographical scale, only the widely distributed European pond turtle (*Emys orbicularis*) can serve for comparison with *T. hermanni*, due to lacking or incomplete data for other species with similar distributions. *Emys orbicularis* and *T. hermanni* both occur on the three major southern European peninsulas

as well as on Corsica and Sardinia. During Pleistocene glaciation both species were forced to retreat to southern refuges (Cheylan 2001; Fritz 2003). With the advent of Holocene warming, *E. orbicularis* underwent rapid range expansion and temperate regions of Europe and adjacent Asia were recolonized from refuges in the Balkans and the northern Black Sea Region (Fritz 2003). By contrast, *T. hermanni* remained more or less confined to its refuges and nearby regions, resulting in a much smaller current range and allopatric and parapatric distribution of haplotype groups and clades. In *E. orbicularis* two or three mtDNA lineages occur, in part syntopically, on each southern peninsula, indicating several distinct refuges in close proximity, and extensive intergradation during Holocene range expansion (Lenk *et al.* 1999; Fritz *et al.* 2005b,c). In *T. hermanni* it is likely that only on the Balkan Peninsula was more than one refuge located, approximately corresponding with the current parapatric ranges of haplotype groups there.

Despite these differences, phylogeographies of *E. orbicularis* and *T. hermanni* share a few similarities. High mountain chains constitute major barriers, separating distinct mtDNA clades of *E. orbicularis* (and other western Palaearctic freshwater turtles: Fritz *et al.* 2006) and haplotype groups of *T. b. boettgeri*. The barrier status of mountain chains could also be true for *T. b. hermanni* if it is hypothesized that the Iberian haplotype H3 is separated from other, more eastern, haplotypes by the Pyrenees and Alps. In this context, identity of *T. b. hermanni* haplotypes on both sides of the Apennines appears contradictory to this hypothesis, but lack of differentiation is not surprising considering that portions of the Apennine mountain chain reach only low to moderate elevations of 500–1000 m, enabling gene flow between both slopes. Another parallel is that on the old western Mediterranean islands Corsica and Sardinia no differentiated (*E. orbicularis*), or only weakly differentiated haplotypes (*T. hermanni*) occur, even though there is evidence for the presence of both species on Corsica since at least the Middle Pleistocene (Hervet 2000, 2001; Hervet & Salotti 2000). In *T. hermanni* the same haplotype (H5) occurs also on Sicily however, while *E. orbicularis* is replaced on this island by another species (*E. trinacris*) harbouring a distinct mtDNA lineage (Fritz *et al.* 2005b).

Systematics

One unexpected result of this study was the conflicting evidence regarding monophyly of *Testudo hermanni boettgeri* haplotypes and possible paraphyly of *T. b. boettgeri* with respect to *T. b. hermanni*. This is suggestive of an incomplete differentiation process despite fully allopatric ranges of both subspecies, and supportive of the view that all populations of *T. hermanni* are conspecific (Fritz *et al.* 2005a; Parham *et al.* 2006). Although *T. b. boettgeri* haplotypes group into distinct geographical clusters in parsimony network analysis, we did not discover

unambiguously supported clades for the west coast and eastern Balkan groups in the phylogenetic analyses (Figs 2–4). This could indicate incipient taxonomic differentiation within *T. b. boettgeri*, caused by limited gene flow through geographical barriers.

From within the range of *T. b. boettgeri*, Perälä (2002) resurrected the taxon *Testudo graeca* var. *hercegovinensis* Werner, 1899 as a full species. Its type locality (Trebinje, Hercegovina, 42°43'N 18°20'E; Werner 1899) lies in the range of our Balkan west coast haplotype group (haplotypes B10–B15), suggesting identity. According to Perälä (2002, 2004), '*T. hercegovinensis*' differs from *T. b. boettgeri* by the absence of inguinal shell scutes. We were able to confirm this character for four tortoises from the northernmost haplotype B13 site (Srbanj, Istria, 45°21'N 13°38'E; black-circled locality 1 in Fig. 1), while inguinal scutes were present in a fifth individual from the same locality. On the other hand, we noted absence of inguinal scutes also in a museum specimen from the eastern Balkans (voucher: Museum of Zoology, Dresden, MTD D 38656, Lafos, Mt. Olympus, approx. 40°10'N 22°20'E), where another haplotype group is found (eastern Balkan group, B1–B7; Fig. 5). Moreover, Perälä (2002) attributed tortoises from a locality (Ulcinj, Montenegro, 41°56'N 19°13'E) within the range of the west coast haplotypes to *T. b. boettgeri*, suggesting that these tortoises possess inguinal scutes. It is apparent that there is no congruence between haplotypes and presence or absence of inguinal scutes.

We conclude that using the classic two subspecies model should be continued for the following reasons: (i) under parsimony, monophyly of both *T. b. hermanni* and *T. b. boettgeri* is reasonably supported; by contrast, west coast and eastern Balkan clades within *T. b. boettgeri* are at best weakly supported under all applied tree-building methods, and haplotypes from the western slope of the Taygetos Mts. are nested within other haplotypes; (ii) in parsimony network analysis, haplotypes of *T. b. hermanni* and *T. b. boettgeri* are separated by at least 16 mutational steps from one another, haplotype groups within *T. b. boettgeri* being separated by a minimum of four or eight steps, arguing for closer relationship between *T. b. boettgeri* haplotypes; and (iii) *T. b. hermanni* and *T. b. boettgeri* represent geographical units easily distinguished by morphological means.

Acknowledgements

Albert Bertolero benefited from a grant from the Spanish Ministry of Education and Science (EX2003-0769), Marcos Martín Sampayo from the IME grant (2004), and Pavel Široký from the IGA VFU grant (2/2004/FVHE). Fieldwork in Spain was financially supported by the Departament d'Universitats, Recerca i Societat de la Informació de la Generalitat de Catalunya and the project CGL2004-04273/BOS of the Spanish Ministry of Education and Science. Henrik Bringsøe,

Joan Budó, Xavier Capalleras, Stefania d'Angelo, Paolo Friz, Miloš Jirků, Martin Kamler, Jan Lehmann, David Modrý, Jean-Pierre Nougarede, Maria Patroescu, Petr Petrás, Bernd Pitzer, Paul-Heinrich Stettler, and Wolfgang Wegehaupt provided blood samples. Thanks for lab work and curation of samples go to Anke Müller and Hedi Sauer-Gürth. Jan-Michael Lange assisted with the production of a map. Stephen D. Busack provided editorial assistance.

References

- Arnold, E. N. (2002). *Reptiles and Amphibians of Europe*. Princeton and Oxford: Princeton University Press.
- Austin, J. J., Arnold, E. N. & Bour, R. (2003). Was there a second adaptive radiation of giant tortoises in the Indian Ocean? Using mitochondrial DNA to investigate speciation and biogeography of *Aldabrachelys*. *Molecular Ecology*, 12, 1415–1424.
- Barth, D., Bernhard, D., Fritzsche, G. & Fritz, U. (2004). The freshwater turtle genus *Mauremys* (Testudines: Geoemydidae) — a textbook example of an east–west disjunction or a taxonomic misconception? *Zoologica Scripta*, 33, 213–221.
- Bour, R. (1996). Une nouvelle espèce de tortue terrestre dans le Péloponnèse (Grèce). *Dumerilia*, 2 (1995), 23–54.
- Bour, R. (2004a). *Testudo boettgeri* Mojsisovics, 1889. *Manouria*, 7 (22), 9–10.
- Bour, R. (2004b). A new character for the identification of populations of the Hermann's tortoise, *Testudo bermanni* Gmelin, 1789. *Salamandra*, 40, 59–66.
- Bringsøe, H., Buskirk, J. R. & Willemssen, R. E. (2001). *Testudo marginata* Schoepff, 1792 — Breitrandschildkröte. In U. Fritz (Ed.) *Handbuch der Reptilien und Amphibien Europas. Band 3/III A: Schildkröten I* (pp. 291–334). Wiebelsheim: Aula-Verlag.
- Caccone, A., Amato, G., Gratry, O. C., Behler, J. & Powell, J. R. (1999). A molecular phylogeny of four endangered Madagascar tortoises based on mtDNA sequences. *Molecular Phylogenetics and Evolution*, 12, 1–9.
- Carranza, S., Arnold, E. N. & Pleguezuelos, J. M. (2006). Phylogeny, biogeography and evolution of two Mediterranean snakes, *Malpolon monspessulanus* and *Hemorrhois biprorepis* (Squamata, Colubridae), using mtDNA sequences. *Molecular Phylogenetics and Evolution* (doi: 10.1016/j.ympev.2006.03.028).
- Cheylan, M. (2001). *Testudo bermanni* Gmelin, 1789 — Griechische Landschildkröte. In U. Fritz (Ed.) *Handbuch der Reptilien und Amphibien Europas. Band 3/III A: Schildkröten I* (pp. 179–289). Wiebelsheim: Aula-Verlag.
- Clement, M., Posada, D. & Crandall, K. A. (2000). tcs: a computer program to estimate gene genealogies. *Molecular Ecology*, 9, 1657–1660.
- Coyne, J. A. & Orr, H. A. (2004). *Speciation*. Sunderland, Massachusetts: Sinauer Associates.
- Delfino, M. (2002). *Erpetofauna italiana del Neogene e del Quaternario*. Modena and Reggio Emilia: Università degli Studi di Modena e Reggio Emilia.
- Feldman, C. R. & Parham, J. F. (2002). Molecular phylogenetics of emydid turtles: taxonomic revision and the evolution of shell kinesis. *Molecular Phylogenetics and Evolution*, 22, 388–398.
- Felsenstein, J. (1985). Confidence limits on phylogenies: an approach using the bootstrap. *Evolution*, 39, 783–791.
- Fritz, U. (2003). *Die Europäische Sumpfschildkröte*. Bielefeld: Laurenti.
- Fritz, U. & Cheylan, M. (2001). *Testudo* Linnaeus, 1758 — Eigentliche Landschildkröten. In U. Fritz (Ed.) *Handbuch der Reptilien und Amphibien Europas. Band 3/III A: Schildkröten I* (pp. 111–124). Wiebelsheim: Aula-Verlag.
- Fritz, U., Guicking, D., Lenk, P., Joger, U. & Wink, M. (2004). When turtle distribution tells European history: mtDNA haplotypes of *Emys orbicularis* reflect in Germany former division by the Iron Curtain. *Biologia*, 59 (Suppl. 14), 19–26.
- Fritz, U., Široký, P., Kami, H. & Wink, M. (2005a). Environmentally caused dwarfism or a valid species — Is *Testudo weissingeri* Bour, 1996 a distinct evolutionary lineage? New evidence from mitochondrial and nuclear genomic markers. *Molecular Phylogenetics and Evolution*, 37, 389–401.
- Fritz, U., Fattizzo, T., Guicking, D., Tripepi, S., Pennisi, M. G., Lenk, P., Joger, U. & Wink, M. (2005b). A new cryptic species of pond turtle from southern Italy, the hottest spot in the range of the genus *Emys*. *Zoologica Scripta*, 34, 351–371.
- Fritz, U., Cadi, A., Cheylan, M., Coïc, C., Détaint, M., Olivier, A., Rosecchi, E., Guicking, D., Lenk, P., Joger, U. & Wink, M. (2005c). Distribution of mtDNA haplotypes (cyt *b*) of *Emys orbicularis* in France and implications for postglacial recolonization. *Amphibia-Reptilia*, 26, 231–238.
- Fritz, U., Barata, M., Busack, S. D., Fritzsche, G. & Castilho, R. (2006). Impact of mountain chains, sea straits and peripheral populations on genetic and taxonomic structure of a freshwater turtle, *Mauremys leprosa*. *Zoologica Scripta*, 35, 97–108.
- Godinho, R., Crespo, E. G., Ferrand, N. & Harris, D. J. (2005). Phylogeny and evolution of the green lizards, *Lacerta* spp. (Squamata: Lacertidae) based on mitochondrial and nuclear DNA sequences. *Amphibia-Reptilia*, 26, 271–285.
- Groombridge, B. (1982). *The IUCN Amphibia — Reptilia Red Data Book. Part 1. Testudines, Crocodylia, Rhynchocephalia*. Gland, Switzerland: IUCN.
- Guicking, D., Lawson, R., Joger, U. & Wink, M. (2006). Evolution and phylogeny of the genus *Natrix*. *Biological Journal of the Linnean Society*, 87, 127–143.
- Gustincich, S., Manfioletti, G., del Sal, G., Schneider, C. & Carninci, C. (1991). A fast method for high-quality genomic DNA extraction from whole human blood. *Bio Techniques*, 11, 298–302.
- Harris, D. J., Znari, M., Macé, J.-C. & Carretero, M. A. (2003). Genetic variation in *Testudo graeca* from Morocco estimated using 12S rRNA sequencing. *Revista Española de Herpetología*, 17, 5–9.
- Hervet, S. (2000). Tortues du Quaternaire de France: critères de détermination, répartition chronologique et géographique. *Mésogée*, 58, 3–47.
- Hervet, S. (2001). Étude du peuplement chélonien de la Corse à partir de la répartition des tortues fossiles de la Méditerranée occidentale. *Bulletin de la Société des Sciences historiques et naturelles de la Corse*, 696/697, 147–163.
- Hervet, S. & Salotti, M. (2000). Les tortues pléistocènes de Castiglione (Oletta, Haute-Corse) et la preuve de leur indigénat en Corse. *Comptes Rendus de l'Académie des Sciences, Série II, Sciences de la Terre et des Planètes*, 330, 645–651.
- Huelsbeck, J. P. & Ronquist, F. (2001). MRBAYES: Bayesian inference of phylogeny. *Bioinformatics*, 17, 754–755.
- de Jong, H. (1998). In search of historical biogeographic patterns in the western Mediterranean terrestrial fauna. *Biological Journal of the Linnean Society*, 65, 99–164.
- van der Kuyl, A. C., Ballasina, D. L. P., Dekker, J. T., Maas, H., Willemssen, R. E. & Goudsmit, J. (2002). Phylogenetic relationships

- among the species of the genus *Testudo* (Testudines: Testudinidae) inferred from mitochondrial 12S rRNA gene sequences. *Molecular Phylogenetics and Evolution*, 22, 174–183.
- Lenk, P., Fritz, U., Joger, U. & Wink, M. (1999). Mitochondrial phylogeography of the European pond turtle, *Emys orbicularis* (Linnaeus 1758). *Molecular Ecology*, 8, 1911–1922.
- Mantziou, G., Poulakakis, N., Lymberakis, P., Valakos, E. & Mylonas, M. (2004). The inter- and intraspecific status of Aegean *Mauremys rivulata* (Chelonia, Bataguridae) as inferred by mitochondrial DNA sequences. *Herpetological Journal*, 14, 35–45.
- Mayr, E. (1942). *Systematics and the Origin of Species from the Viewpoint of a Zoologist*. New York: Columbia University Press.
- Mayr, E. (1963). *Animal Species and Evolution*. Cambridge: Belknap Press.
- Mirimin, L., Vernesi, C., Bertolucci, C., Mazzotti, S. & Bertorelle, G. (2004). Mitochondrial DNA variation and divergence in three Hermann's tortoise (*Testudo hermanni*) populations. *Italian Journal of Zoology, Supplement*, 2, 199–201.
- Palkovacs, E. P., Gerlach, J. & Caccone, A. (2002). The evolutionary origin of Indian Ocean tortoises (*Dipsosaurus*). *Molecular Phylogenetics and Evolution*, 24, 216–227.
- Parham, J. F., Macey, J. R., Papenfuss, T. J., Feldman, C. R., Türkozan, O., Polymeni, R. & Boore, J. (2006). The phylogeny of Mediterranean tortoises and their close relatives based on complete mitochondrial genome sequences from museum specimens. *Molecular Phylogenetics and Evolution*, 38, 50–64.
- Perälä, J. (2002). Biodiversity in relatively neglected taxa of *Testudo* L., 1758 s. 1. *Chelonia*, 3, 40–53.
- Perälä, J. (2004). *Testudo hercegovinensis* Werner, 1899. *Manouria*, 7 (22), 19–20.
- Posada, D. & Crandall, K. A. (1998). MODELTEST: testing the model of DNA substitution. *Bioinformatics*, 14, 817–818.
- Posada, D. & Crandall, K. A. (2001). Intraspecific gene genealogies: trees grafting into networks. *Trends in Ecology and Evolution*, 16, 37–45.
- Poulakakis, N., Lymberakis, P., Valakos, E., Pafilis, P., Zouros, E. & Mylonas, M. (2005). Phylogeography of Balkan wall lizard (*Podarcis taurica*) and its relatives inferred from mitochondrial DNA sequences. *Molecular Ecology*, 14, 2433–2443.
- Rögl, F. (1998). Paleogeographic considerations for Mediterranean and Paratethys seaways (Oligocene to Miocene). *Annalen des Naturhistorischen Museums Wien*, 99A, 279–310.
- Sambrook, J., Fritsch, E. F. & Maniatis, T. (1989). *Molecular Cloning: a Laboratory Manual*, 2nd edn. Cold Spring Harbor, N. Y.: Cold Spring Harbor Laboratory Press.
- Spinks, P. Q., Shaffer, H. B., Iverson, J. B. & McCord, W. P. (2004). Phylogenetic hypotheses for the turtle family Geoemydidae. *Molecular Phylogenetics and Evolution*, 32, 164–182.
- Swofford, D. L. (2002). *PAUP*. Phylogenetic Analysis Using Parsimony (*and Other Methods)*, Version 4.0b10. Sunderland, Massachusetts: Sinauer Associates.
- Swofford, D. L., Olsen, G. J., Waddell, P. J. & Hillis, D. M. (1996). Phylogenetic inference. In D. M. Hillis, C. Moritz & B. K. Mable (Eds) *Molecular Systematics*, 2nd edn (pp. 407–543.) Sunderland, Massachusetts: Sinauer Associates.
- Wermuth, H. (1952). *Testudo hermanni robertmertensi* n. subsp. und ihr Vorkommen in Spanien. *Senckenbergiana*, 33, 157–164.
- Werner, F. (1899). Beiträge zur Kenntniss der Reptilien- und Batrachierfauna der Balkanhalbinsel. *Wissenschaftliche Mittheilungen aus Bosnien und der Hercegovina*, 6, 817–841.